HALOPAR 20 E27

Halogen lamps with parabolic reflector PAR20, with E27 screw base



Areas of application

- General illumination
- Kitchen lighting
- Dining table lighting
- Object lighting
- Accent lighting
- Shops
- Restaurants, hotels and similar prestigious applications

Product benefits

- Brilliant accent light
- With whole glass reflector for brilliant lighting effects
- Instant 100 % light, no warm-up time
- Approved for use in open luminaires (to IEC 60598-1)
- Contains no mercury
- UV filter

Product features

- Average life: 2,000 h
- 100 % dimmable
- Perfect color rendering (R_a : 100)
- Color temperature: 2,800 K

Product family datasheet

Technical data

Product description	Electrical data				Photometrical data		Light technical data			Dimensions & weight	
	Nominal wattage	Nominal voltage	Rated wattage	Power factor λ	Color temperature	Color rendering index Ra	Beam angle	Starting time	Warm-up time (60 %)	Diameter	Overall length
HALOPAR 20 50 W 230 V 10° E27 ¹⁾	50.0 W	230 V	50.00 W	1.00	2800 K	100	10 °	0.0 s	0.00 s	64.5 mm	90.0 mm
HALOPAR 20 50 W 240 V E27 ¹⁾	50.0 W	240 V	50.00 W	1.00	2800 K	100	30 °	0.0 s	0.00 s	64.5 mm	90.0 mm
HALOPAR 20 50 W 240 V 30° E27 ¹⁾	50.0 W	240 V	50.00 W	1.00	2800 K	100	30 °	0.0 s	0.00 s	64.5 mm	90.0 mm

Product description	Lifespan				Additional product data			Capabilities	
	Nominal lamp life time	Rated lamp life time	Number of switching cycles	Lumen main. fact. at end of nom. life time	Base (standard designation)	Lamp mercury content	Mercury-free	Burning position	Dimmable
HALOPAR 20 50 W 230 V 10° E27 ¹⁾	2000 h	2000 h	50000 ²⁾	0.75	E27	0.0 mg	Yes	Any	Yes
HALOPAR 20 50 W 240 V E27 ¹⁾	2000 h	2000 h	50000 ²⁾	0.75	E27	0.0 mg	Yes	Any	Yes
HALOPAR 20 50 W 240 V 30° E27 ¹⁾	2000 h	2000 h	50000 ²⁾	0.75	E27	0.0 mg	Yes	Any	Yes

Product description	Certificates & standards		Country specific categorizations
	Energy efficiency class	Energy consumption	ILCOS
HALOPAR 20 50 W 230 V 10° E27 ¹⁾	D	50 kWh/1000h	HAGS/UB-50-230-E27-64,5/10
HALOPAR 20 50 W 240 V E27 ¹⁾	D	50 kWh/1000h	HAGS/UB-50-240-E27-64,5/30
HALOPAR 20 50 W 240 V 30° E27 ¹⁾	D	50 kWh/1000h	HAGS/UB-50-240-E27-64,5/30

¹⁾ Not suitable for outdoor use or damp conditions/Banned from 1.9.2016 as per EU phase-out plan

²⁾ At 1 min on / 3 min off

Product family datasheet

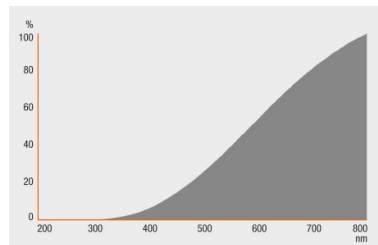
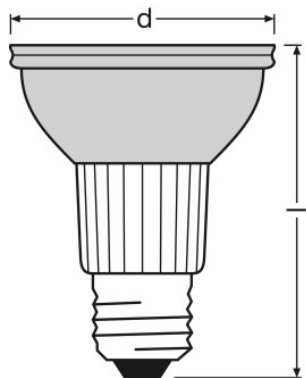

HALOPAR 20 50 W 230 V 10° E27,
HALOPAR 20 50 W 240 V E27,
HALOPAR 20 50 W 240 V 30° E27

HALOPAR 20 50 W 230 V 10° E27,
HALOPAR 20 50 W 240 V 30° E27

Application advice

For more detailed application information and graphics please see product datasheet.

Logistical Data

Product code	Product description	Packaging unit (Pieces/Unit)	Dimensions (length x width x height)	Volume	Gross weight
4050300406800	HALOPAR 20 50 W 230 V 10° E27	Shipping carton box 15	331 mm x 105 mm x 199 mm	6.92 dm ³	2216.00 g
4008321286895	HALOPAR 20 50 W 240 V E27	Shipping carton box 15	331 mm x 199 mm x 105 mm	6.92 dm ³	2021.00 g

Product family datasheet

Product code	Product description	Packaging unit (Pieces/Unit)	Dimensions (length x width x height)	Volume	Gross weight
4050300435282	HALOPAR 20 50 W 240 V 30° E27	Shipping carton box 15	331 mm x 105 mm x 199 mm	6.92 dm ³	2021.00 g

The mentioned product code describes the smallest quantity unit which can be ordered. One shipping unit can contain one or more single products. When placing an order, for the quantity please enter single or multiples of a shipping unit.

References / Links

For light distribution curves see

▶ www.osram.com

Disclaimer

Subject to change without notice. Errors and omission excepted. Always make sure to use the most recent release.