HALOPAR 16 GU10/GZ10 STAR

Halogen lamps with parabolic reflector PAR16, with GU10/GZ10 base



Areas of application

- Shops
- Restaurants, hotels and similar prestigious applications

Product benefits

- Brilliant accent light
- With whole glass reflector for brilliant lighting effects
- Approved for use in open luminaires (to IEC 60598-1)
- No transformer required
- UV filter
- Robust filament design thanks to innovative, unique bulb pinch technology

Product features

- Average life: 2,000 h
- 100 % dimmable
- Color rendering index R_a : 100
- Base: GU10, GZ10

Product family datasheet

Technical data

Product description	Electrical data				Photometrical data		Light technical data			Dimensions & weight	
	Nominal wattage	Nominal voltage	Rated wattage	Power factor λ	Color temperature	Color rendering index Ra	Beam angle	Starting time	Warm-up time (60 %)	Diameter	Overall length
HALOPAR 16 ST 50 W 240 V 30° GU10	50.0 W	240 V	50.00 W	1.00	2800 K	100	30 °	0.0 s	0.00 s	50.7 mm	58.0 mm
HALOPAR 16 ST 50 W 240 V GU10	50.0 W	240 V	50.00 W	1.00	2800 K	100	30 °	0.0 s	0.00 s	50.7 mm	58.0 mm

Product description	Lifespan				Additional product data			Capabilities	
	Nominal lamp life time	Rated lamp life time	Number of switching cycles	Lumen main. fact. at end of nom. life time	Base (standard designation)	Lamp mercury content	Mercury-free	Burning position	Dimmable
HALOPAR 16 ST 50 W 240 V 30° GU10	1000 h	1000 h	25000 ¹⁾	0.75	GU10	0.0 mg	Yes	Any	Yes
HALOPAR 16 ST 50 W 240 V GU10	1000 h	1000 h	25000 ¹⁾	0.75	GU10	0.0 mg	Yes	Any	Yes

Product description	Certificates & standards		Country specific categorizations
	Energy efficiency class	Energy consumption	ILCOS
HALOPAR 16 ST 50 W 240 V 30° GU10	D	50 kWh/1000h	HAGS/UB-50-240-GU10-51/30
HALOPAR 16 ST 50 W 240 V GU10	D	50 kWh/1000h	HAGS/UB-50-240-GU10-51/30

¹⁾ At 1 min on / 3 min off

Product family datasheet

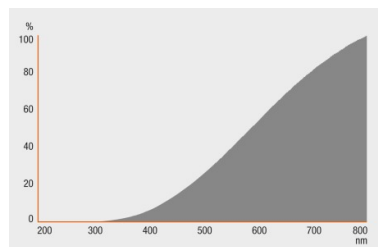
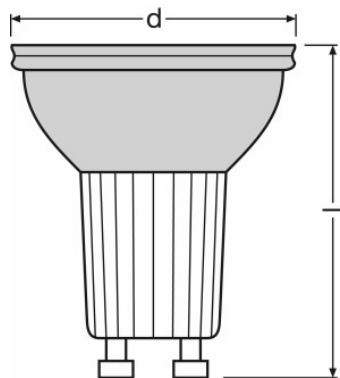

HALOPAR 16 ST 50 W 240 V 30°
GU10, HALOPAR 16 ST 50 W 240 V
GU10

HALOPAR 16 ST 50 W 240 V 30° GU10

Application advice

For more detailed application information and graphics please see product datasheet.

Logistical Data

Product code	Product description	Packaging unit (Pieces/Unit)	Dimensions (length x width x height)	Volume	Gross weight
4008321226563	HALOPAR 16 ST 50 W 240 V 30° GU10	Shipping carton box 20	290 mm x 132 mm x 254 mm	9.72 dm ³	1116.20 g
4008321280220	HALOPAR 16 ST 50 W 240 V GU10	Shipping carton box 10	258 mm x 113 mm x 77 mm	2.24 dm ³	585.00 g

Product family datasheet

Product code	Product description	Packaging unit (Pieces/Unit)	Dimensions (length x width x height)	Volume	Gross weight
--------------	---------------------	------------------------------	--------------------------------------	--------	--------------

The mentioned product code describes the smallest quantity unit which can be ordered. One shipping unit can contain one or more single products. When placing an order, for the quantity please enter single or multiples of a shipping unit.

References / Links

For light distribution curves see

▶ www.osram.com

Disclaimer

Subject to change without notice. Errors and omission excepted. Always make sure to use the most recent release.